

**American Society of Safety Engineers**  
Professional Development Conference June 13-16, 2010



**Session No. 101E**

# **Fire Protection**

**Stephen J. Musur CSP, CFPS**

**Chubb Group of Insurance Companies**

# Fundamentals of SH&E



This presentation is for informational purposes only and has an edition date of June, 2010. This presentation is necessarily general in content and intended to provide an overview of certain aspects of fire science. No liability is assumed by reason of the information this document contains.

Chubb refers to the insurers of the Chubb Group of Insurance Companies. Coverage may not be available in all jurisdictions. This presentation is the property of Chubb. Any use of this presentation without Chubb's prior, written consent is prohibited.



# Agenda

## Introduction

- Science of Fire
- Fire Controls
- Fire Protection
  - Detection / Suppression
- Testing - Maintenance
- Warehousing / Storage
- Questions

# What is Fire ?



# Classic Definition

Fire is rapid oxidation with the evolution of heat and light



# The Fire Triangle



# Triangle? Not a Tetrahedron?

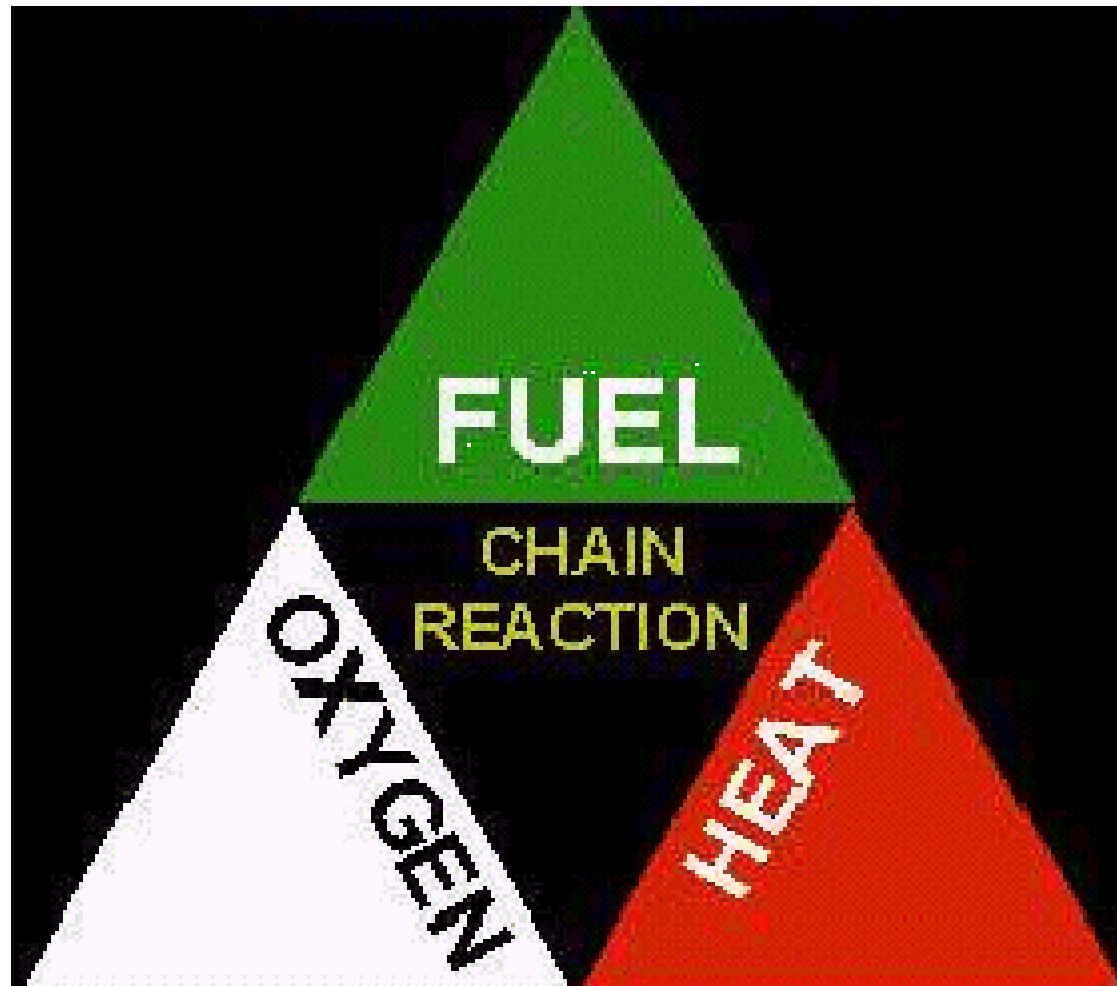

# What's Burning?



June 13 - 16, 2010





# Pyrolysis

- Some of the heat is lost (convective)
- Some of the heat goes back into the system (conductive)
- Heat produces vapors
- Vapors ignite and propagate



# Vapors

## Flammable Range LFL - UFL, LEL - UEL

- Lean
- Rich

EXPLOSIVE RANGE OF GASOLINE

LEL vs. UEL

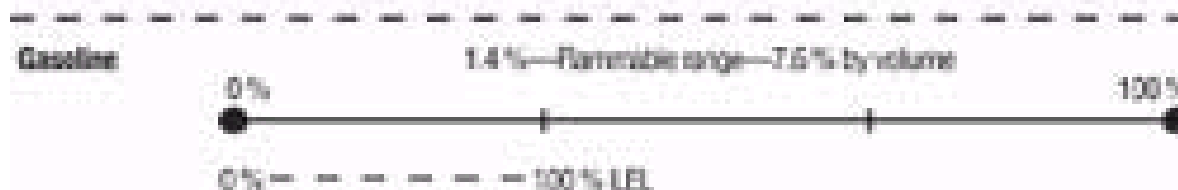
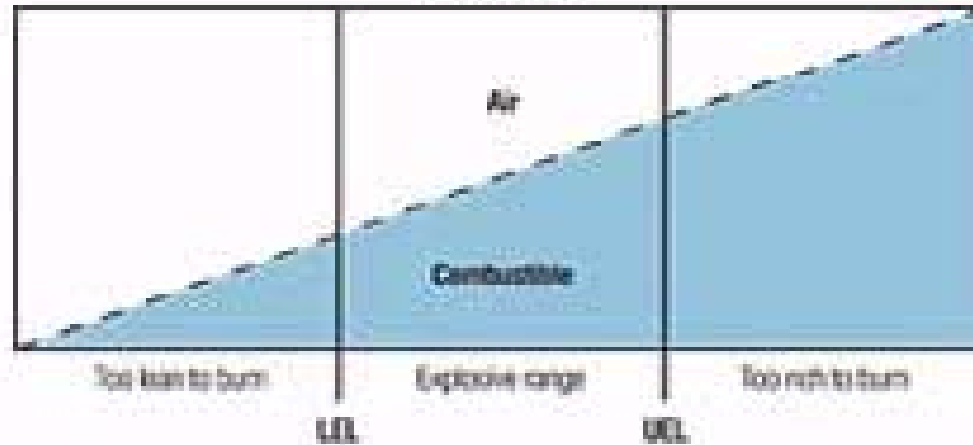

# So Far



- **Defined Fire**
- **Know what is burning**
- **Concept of Flammability Range**

# Control

- Remove one or more legs of the triangle
- Omit the Fuel
- Inert the Atmosphere
- Cool the Reaction
- Interfere with the combustion process



# Applied Controls -- Fuel

- Segregate fuel from processes
- Minimize the amount of fuel
- Use less combustible materials
- Housekeeping - Dusts

# Applied Controls -- Oxygen



- Can the process operate rich?
- Can the process operate lean?
- Inert the operation –  $N_2$ ,  $CO_2$

# Applied Controls -- Heat

- Exothermic processes
- Frictional heat
- Chemical heat
- Sparks - Electrical



# Applied Controls -- Heat

- Sparks - Welding, Hot Work
- Grinding
- Open Flames
- Lightning
- Smoking







# Applied Controls -- Chain Reaction

- **Less Hazardous Materials**
  - **Water Soluble vs. Oil Based**
    - **Paints, Cutting Oils, Lubricants, Inks Etc.**
- **Fire Resistive Materials**
  - **Phenols, PVC's vs. Polyethylene, Styrene**
  - **Inerting Fillers for Plastic**
  - **Intumescent**

# Applied Controls -- Management



## Written Procedures

- Air Sampling
- Hot Work
- Self Inspections
- Outside Contractors

FOR ALL CUTTING/WELDING OPERATIONS

SPECIAL INSTRUCTIONS

**Cutting/Welding Permit**  
Applies Only to Area Specified Below

SEE INSTRUCTIONS ON REVERSE SIDE

**SECTION A**

LOCATION	JOB OR WVA NUMBER
----------	-------------------

**INSTRUCTIONS**

1. Supervisor completes section to be used and then fills in Sections A & C.
2. Supervisor retains the top copy of the form and issues the permit card (Sections B & C) to the worker.
3. Worker completes Section C, marks Section B in the work area, and returns Section C to the supervisor.
4. Section B remains at the work area until it is picked up one hour after work is completed, and is then returned to the Supervisor.

**IS THERE A SAFER WAY?**

# So Far



- Principles of Extinguishment
- Know what is burning
- Concept of Flammability Range
- Applied Controls

# System Controls -- Devices

- Fire Detection
- Fire Suppression



# System Controls -- Devices

## Fire Detection

- **Smoke**
  - Ionization, Photoelectric
- **Heat**
  - Restorable, Rate of Rise
- **Beam**
  - Obscuration
- **Flame**
- **IR**



# System Controls -- Devices

## Four Stages of a Fire

- **Incipient**
  - Microseconds to days
- **Smoldering**
  - Microseconds
- **Flaming**
- **High Heat**



# Time -Temperature Curve

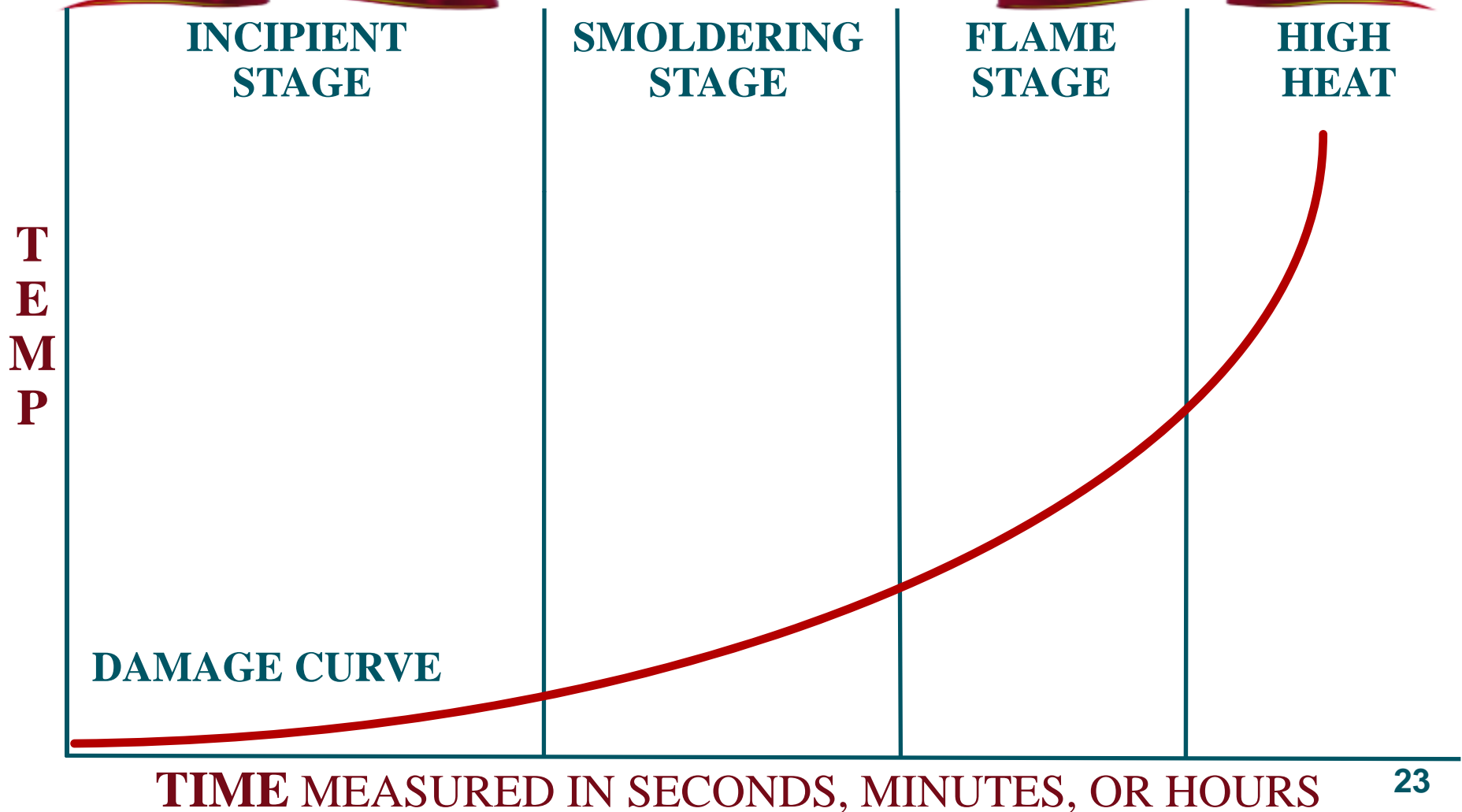



June 13 - 16, 2010

# Time -Temperature Curve

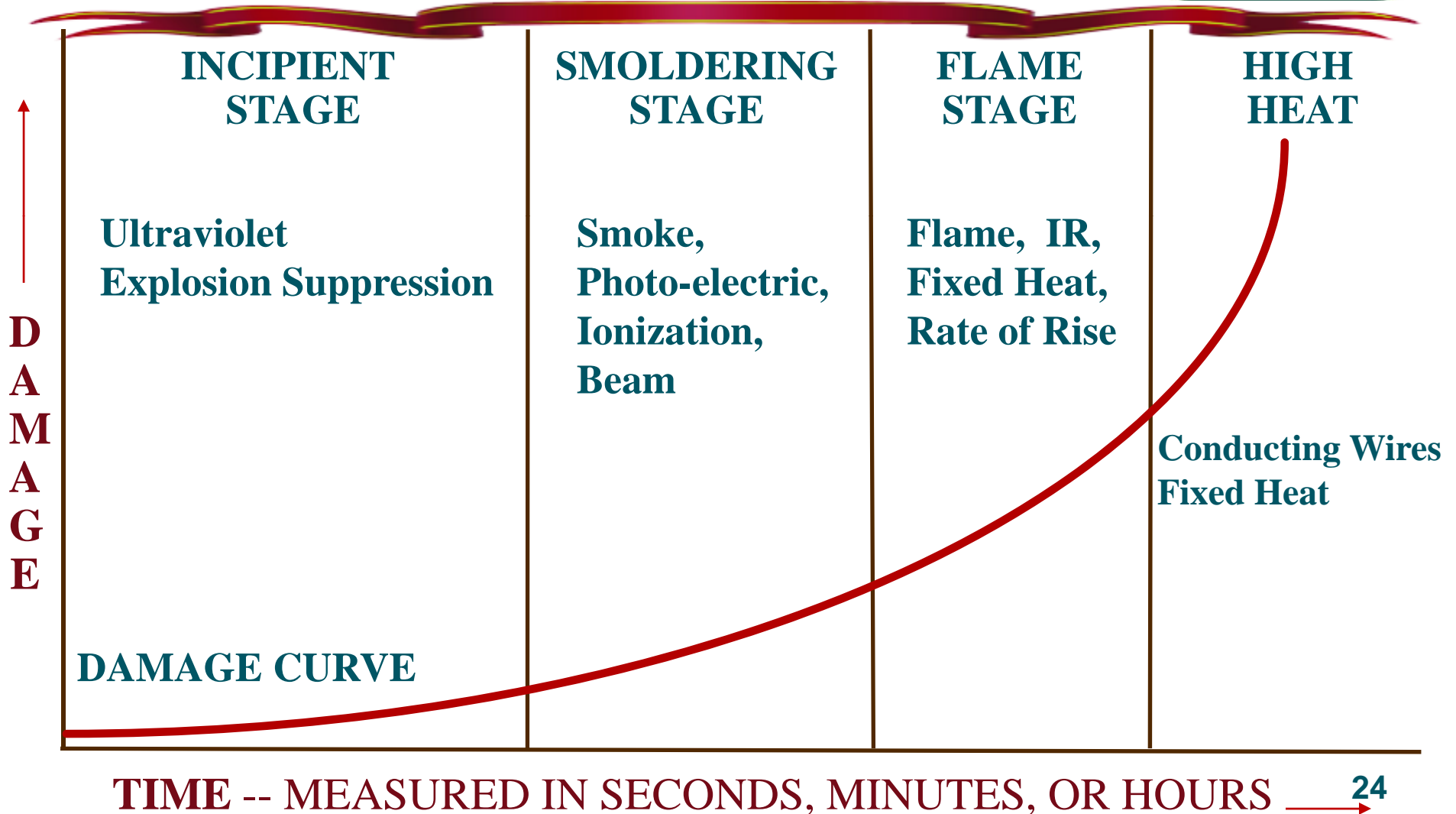



# So Far

- Principles of Extinguishment
- Know what is burning
- Concept of Flammability Range
- Applied Controls
- Stages of a Fire
- Fire Detection

# System Controls - Fixed Suppression



June 13 - 16, 2010

## Sprinkler Systems

- Wet
- Dry
- Anti-freeze
- Deluge
- Pre-action
- Combined Dry / Pre-action
- Cycling On-Off
- Ref: NFPA 13

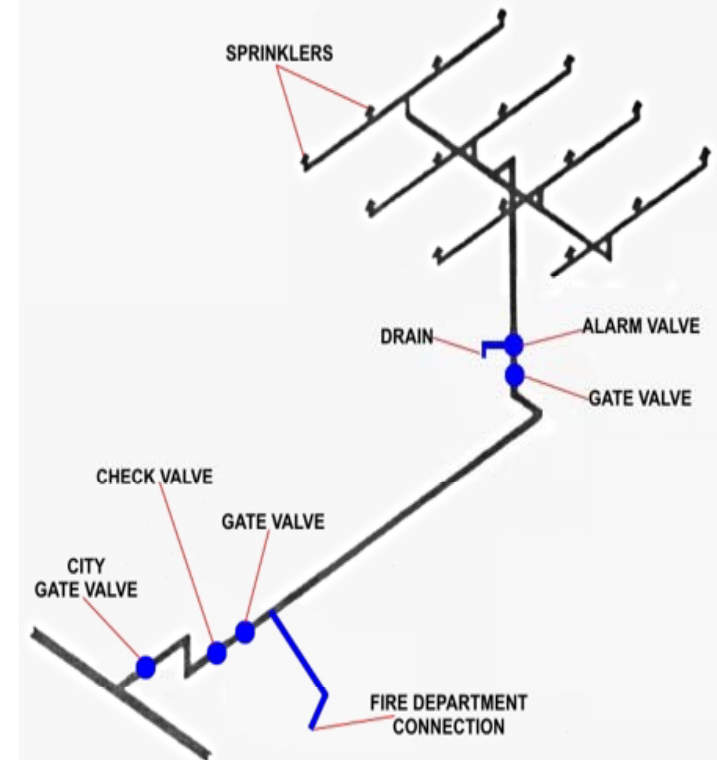

# System Controls - Fixed Suppression

## Sprinkler Systems

- **Wet**
  - **Most Common**
  - **Water in the pipes**
  - **Very efficient**
  - **Requires Heat**

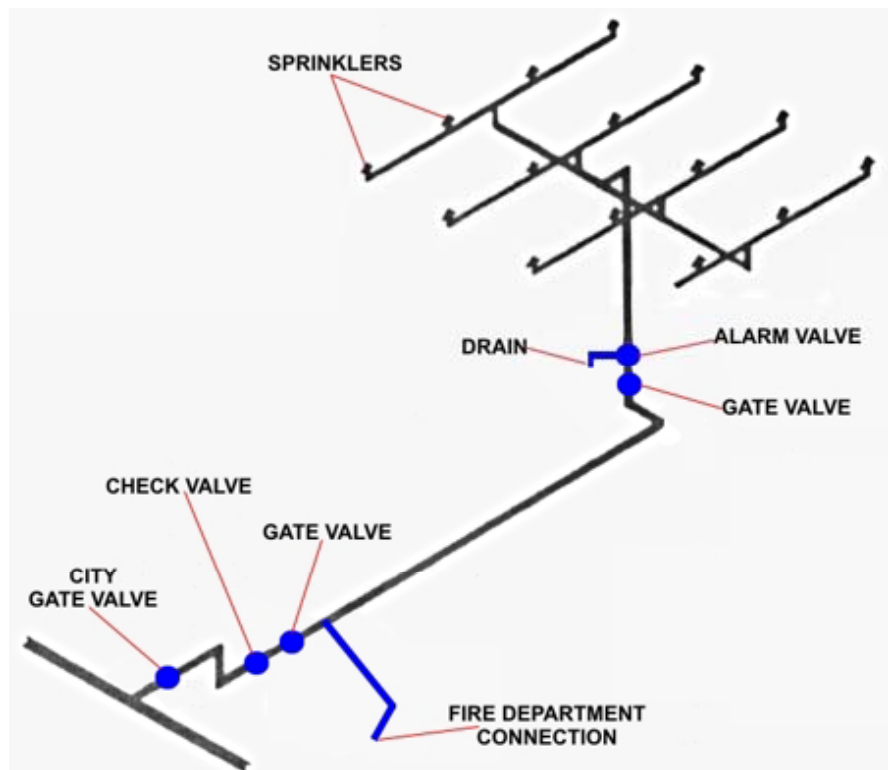

# System Controls - Fixed Suppression

## Sprinkler Systems

- **Dry**
  - Compressed air in pipes
  - Needs more devices
  - Used in areas subject to freezing
  - Limited in size

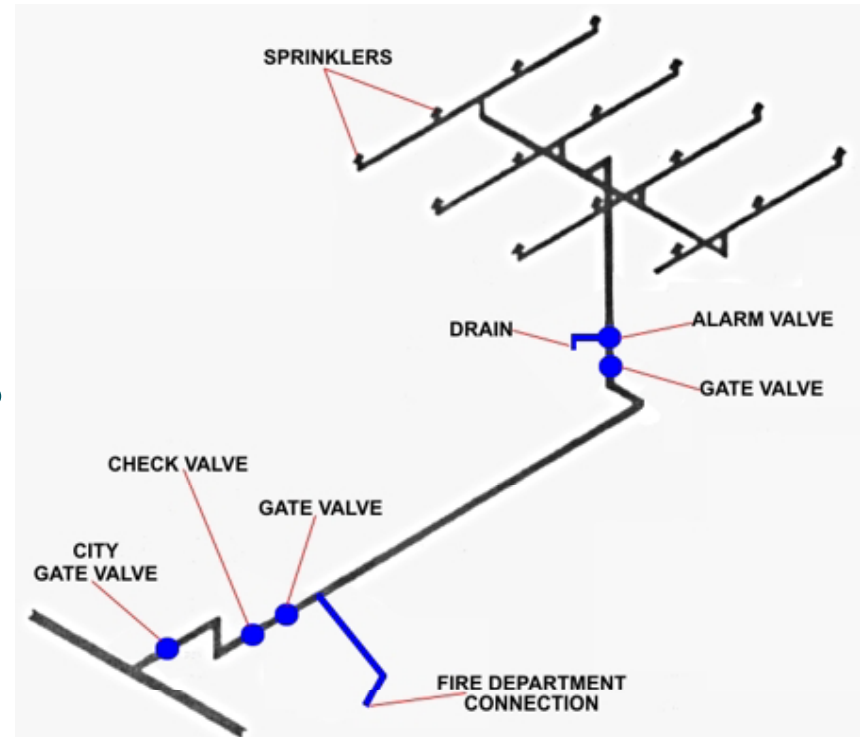

# System Controls - Fixed Suppression

## Sprinkler Systems

- **Anti-Freeze**
  - Filled with a glycol solution
  - Limited in size
  - Some applications to storage occupancies

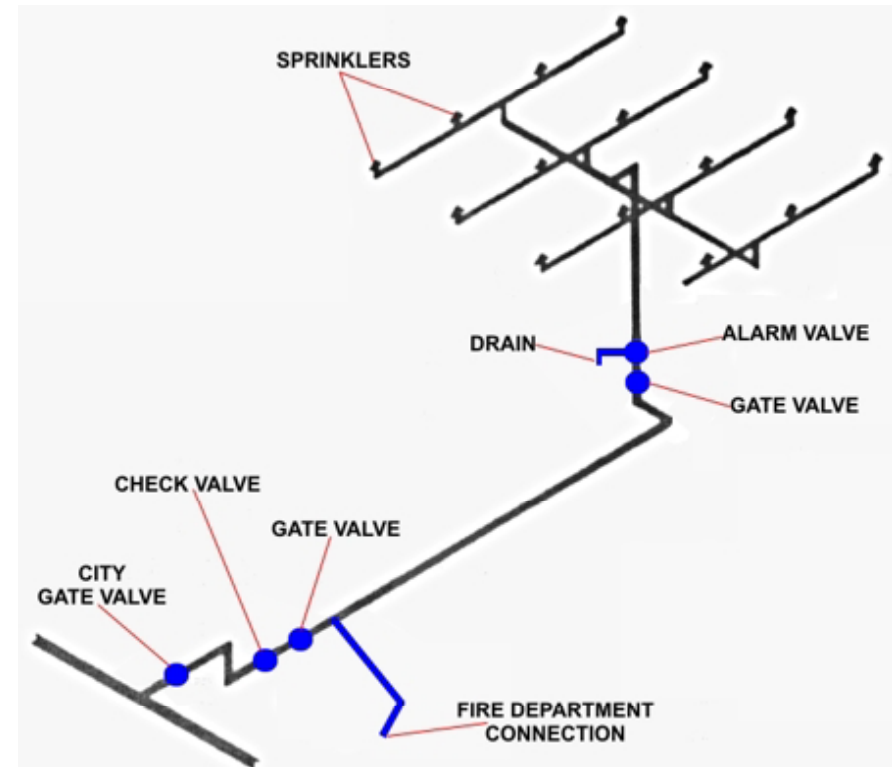

# System Controls - Fixed Suppression

## Sprinkler Systems

- Deluge
  - Nothing in pipes
  - Sprinklers are open
  - Used in High Hazard areas / processes
- Requires an actuation system

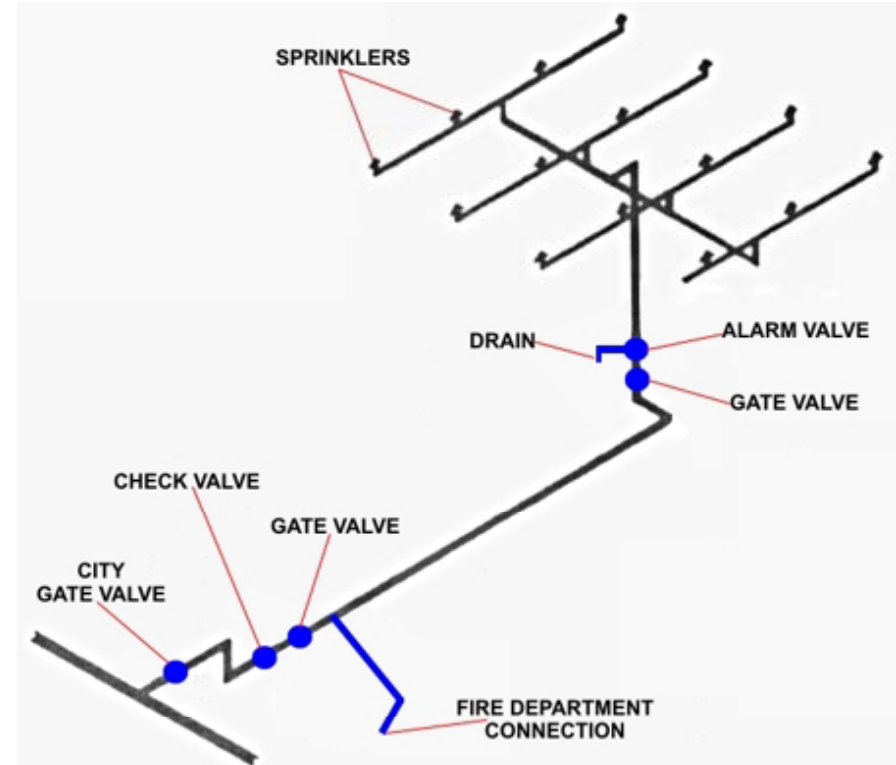

# System Controls - Fixed Suppression

## Sprinkler Systems

- **Pre-Action**
  - Pipes filled with a compressed air
  - Requires an actuation system
  - Minimizes water damage

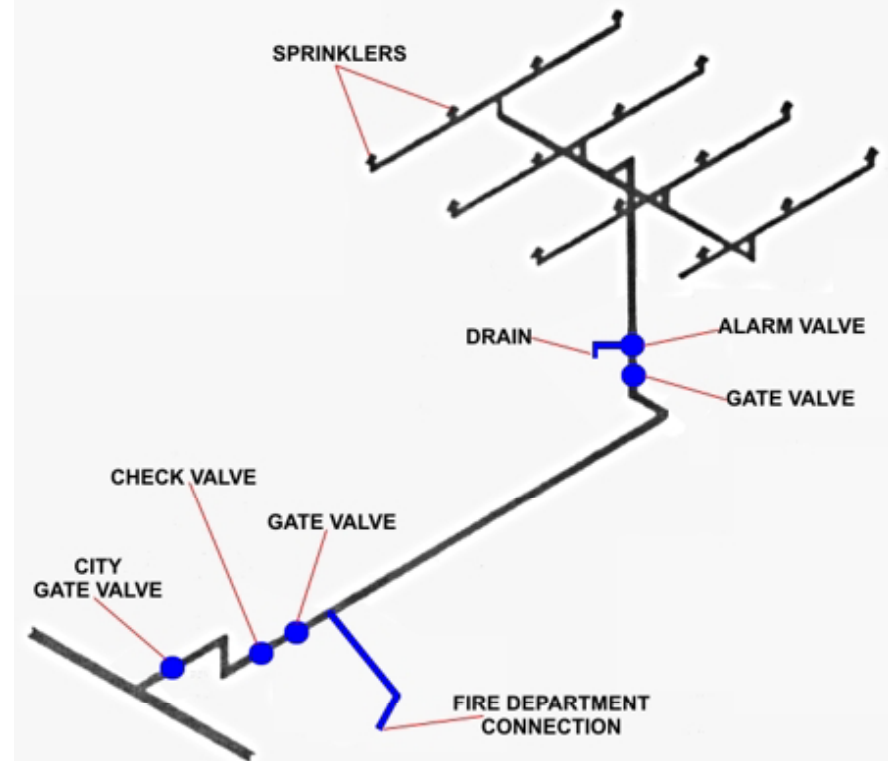

# System Controls - Fixed Suppression



## Terminology

- **Pipe Schedule System**
  - Pre – 1972
  - Pipes Sized per a schedule
  - Pipes Sized based on Occupancy
    - Light, Ordinary Hazard, Extra Hazard
- **Hydraulically Calculated Systems**
  - Pipes sized on friction loss
  - Loops and Grids **MUST** be Calculated
  - Risers Clearly Placarded with Design Info



# System Controls - Fixed Suppression



June 13 - 16, 2010

## Terminology

- Branch lines
- Crossmains
- Feedmains
- Risers
- Sprinklers

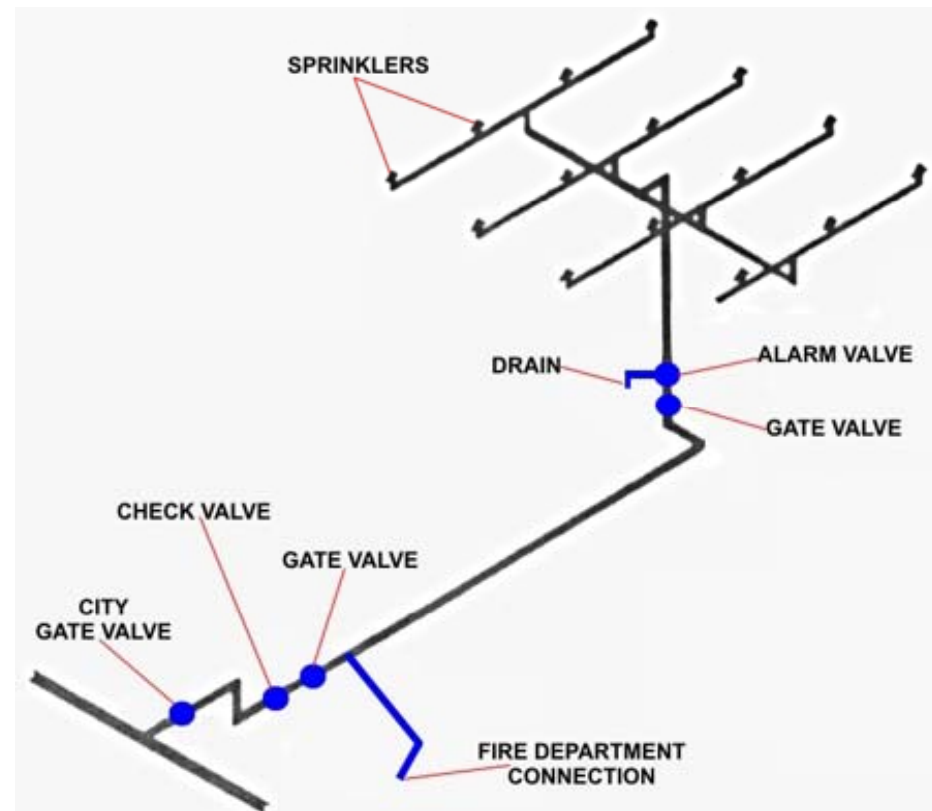

# System Controls - Fixed Suppression

## Sprinkler Systems

- Tree Systems
- Looped Systems
- Gridded Systems

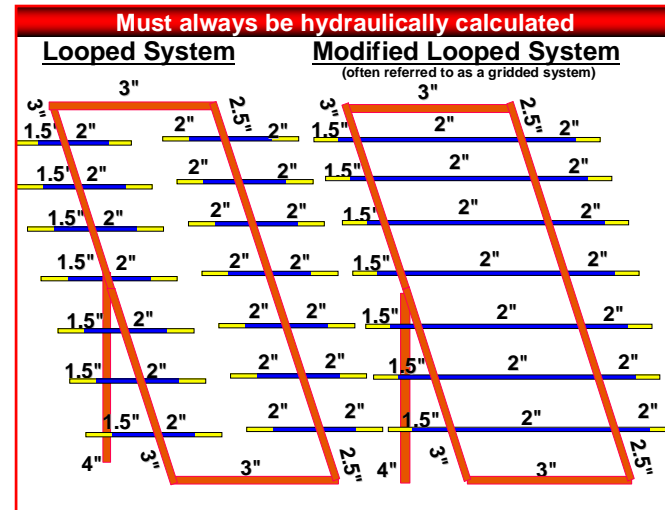
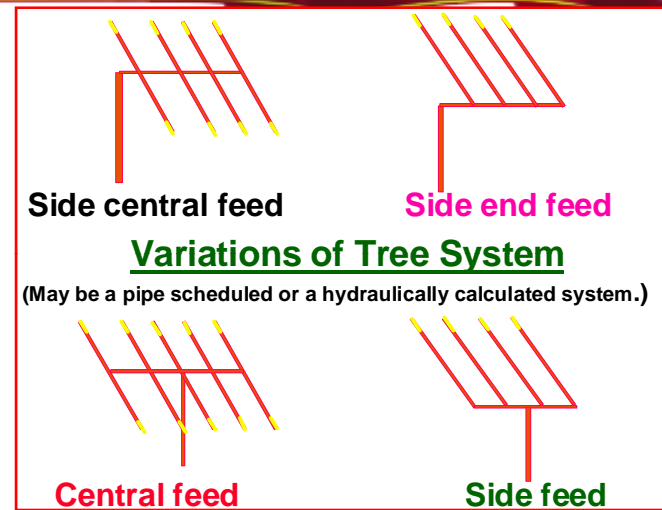
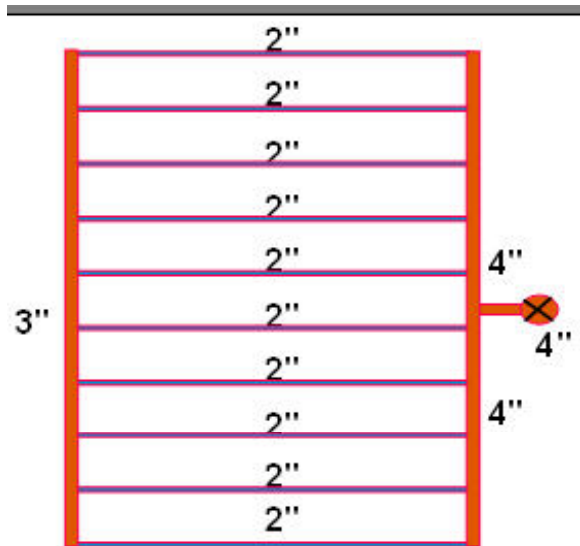

# So Far

- Principles of Extinguishment
- Know what is burning
- Concept of Flammability Range
- Applied Controls
- Stages of a Fire
- Fire Detection
- Sprinkler Systems

# System Controls - Fixed Suppression



## Sprinklers

- Upright
- Pendant
- Special Application

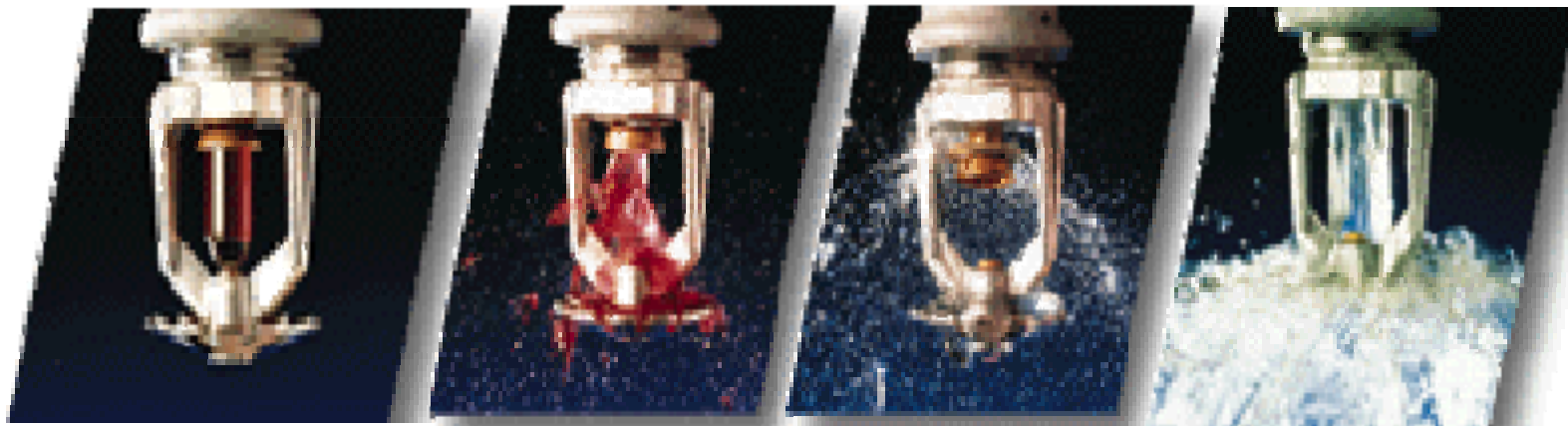

# System Controls - Fixed Suppression

## Sprinklers

- Upright
- Pendant
- Quick Response
- Fast Response
- Nozzles
- Storage
- Special Application

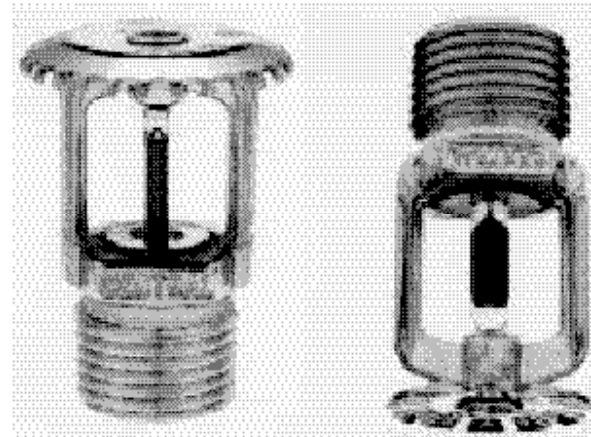

Fast response  
3-mm bulb

Standard response  
5-mm bulb

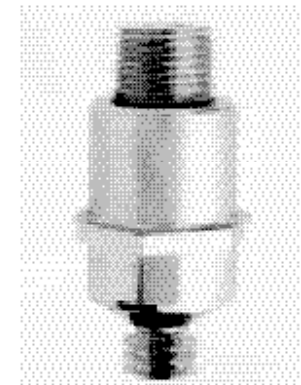

Fast response element

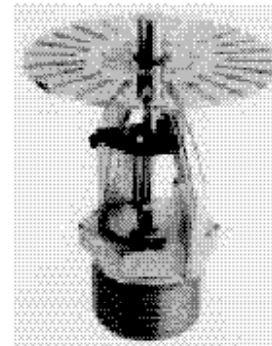

Fast response link



Standard response  
solder link sprinkler

# System Controls - Fixed Suppression

## Sprinklers

- **Good for 50 years**
  - Must be tested
- **Orientation**
  - Replace like kind
- **Obstructions**
  - Adequate Clearance

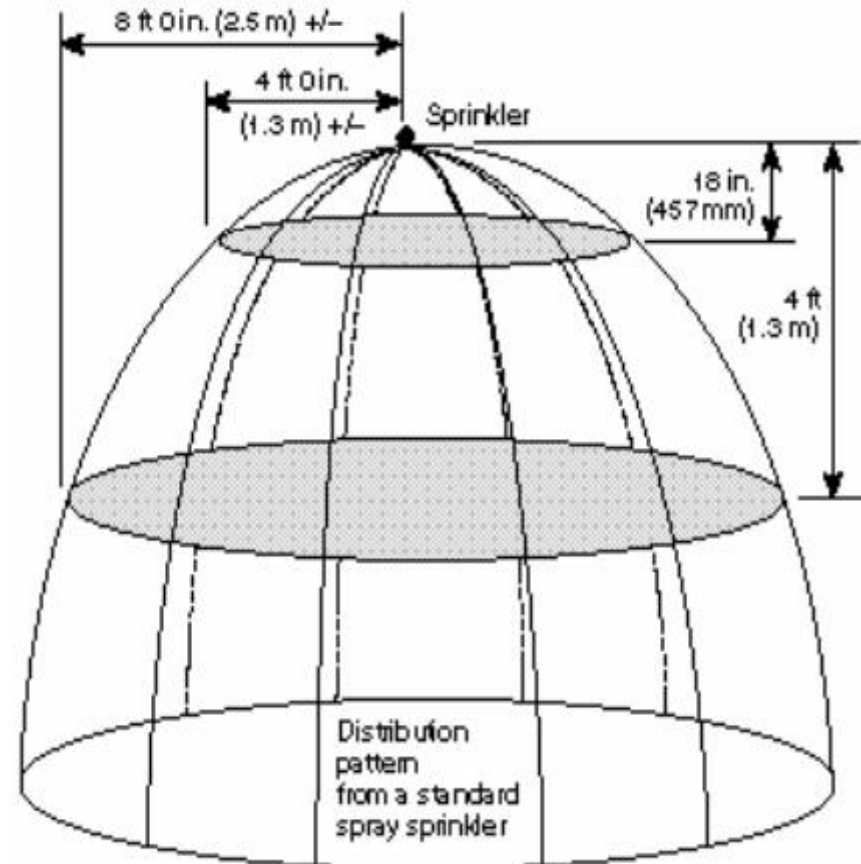

# So Far

- Principles of Extinguishment
- Know what is burning
- Concept of Flammability Range
- Applied Controls
- Stages of a Fire
- Fire Detection
- Sprinkler Systems

# System Controls - Fixed Suppression

## Other Systems

- CO2
- Halon 1301 1211
- Clean Agents
  - FM 200
  - Inergen
  - Sapphire
- Dry Chemical
- Liquid Salts
- Explosion Suppression





# System Controls - Fixed Suppression



## Other Systems

- Used Where water damage is an issue
- Can be used in inhabited areas
- Preferred for Specific Hazards
- Special Maintenance Needs



# So Far

- Principles of Extinguishment
- Know what is burning
- Concept of Flammability Range
- Applied Controls
- Stages of a Fire
- Fire Detection
- Sprinkler Systems
- Special Extinguishing Systems

# System Controls - First Attack

- **Hand Held Extinguishers**

- Water
- Dry Chemical
- CO<sub>2</sub>
- Metal Powders
- Liquid Salts

- **Class Of Fire**

- “A”            Paper, Cloth, Wood
- “B”            Oils, Grease
- “C”            Electrical
- “D”            Metal
- “K”            Kitchens



# System Controls - First Attack



## • Hand Held Extinguishers

- Placement
- Size
- Correct Extinguisher for Class of Fire
- Employee Training
- Maintenance
- Obsolete Extinguishers



# Maintenance

- **Maintenance for Suppression Systems**
  - Prescribed by NFPA 25
- **Maintenance for Detection Systems**
  - Prescribed by NFPA 72
- **Fire Extinguishers**
  - Prescribed by NFPA 10
- **Document the Work / Tests**

# So Far

- Principles of Extinguishment
- Know what is burning
- Concept of Flammability Range
- Applied Controls
- Stages of a Fire
- Fire Detection
- Sprinkler Systems
- Special Extinguishing Systems
- Hand Held Extinguishers

**WHEW !!**



# Storage and Warehousing

## NFPA Commodity Classifications

- **Class I**  
Noncombustible product on pallet or in carton
- **Class II**  
Noncombustible product in wood or multi-layered carton
- **Class III**  
Combustible product, with or without cartons, pallets and not > 5% Class A plastic

# Storage and Warehousing

## NFPA Commodity Classifications

- **Class IV**

**Product with 25% (vol.) 15% (wt.) Grp. A Plastic**

- **Plastics**

Group "A" POLY – anything, Styrene

Group "B" Nylon, Rubber

Group "C" Phenols, CPVC

- **Idle Pallets**



# Storage and Warehousing

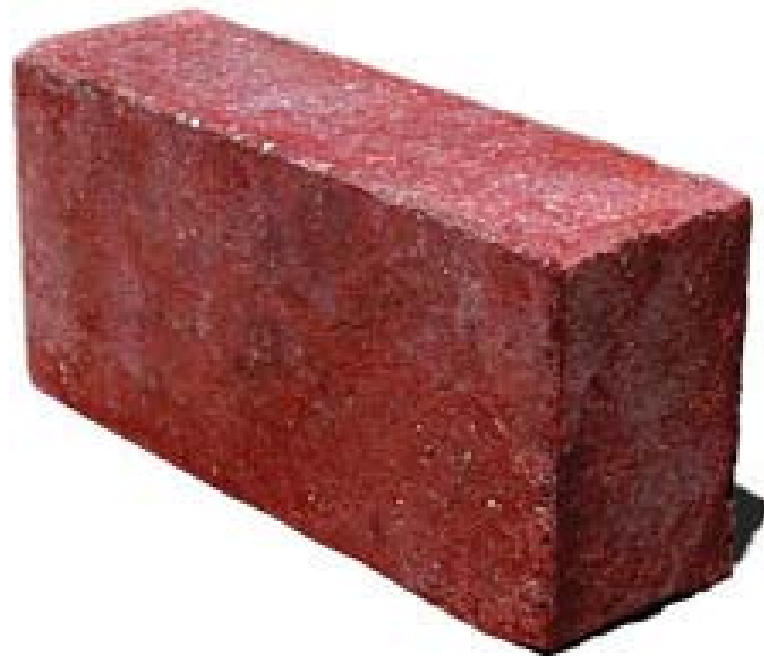

**Remember -- *The Brick***

# Storage and Warehousing

## Protection Based On:

- What is being Stored?
  - Commodity Class (Worst Class)
- How is it being Stored?
  - Stock pile. Racks, Shelves, Multi-row Racks
- How High is it being Stored?
  - Measured from floor to top of storage
- How High is the ceiling?



# Changes in Storage and Warehousing



- Metal vs. Plastic
- Stock Pile vs. Rack
- Rack vs. Multi-Row Racks
- 12', 20', 22', 25' Storage?



In general change is *Not* good

# Whew !! – Were Finished

- Principles of Extinguishment
- Know what is burning
- Concept of Flammability Range
- Applied Controls
- Stages of a Fire
- Fire Detection
- Sprinkler Systems
- Special Extinguishing Systems
- Hand Held Extinguishers
- Storage

# Questions

